

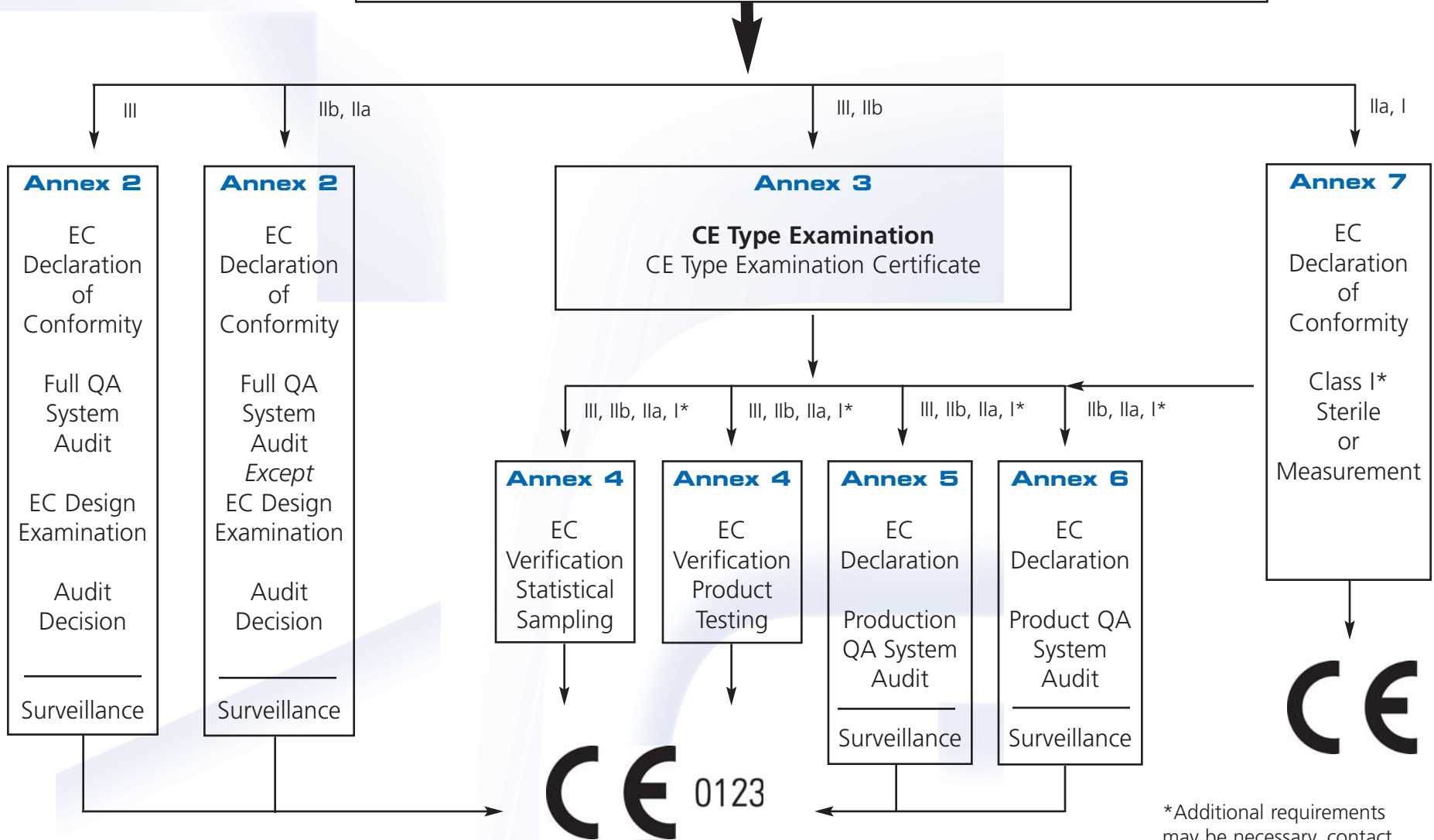

Medical Devices Directive 93/42/EEC Conformity



*Additional requirements may be necessary, contact TÜV for more details.